

FE analysis of tube forming process with experimental verification

V. Mandic ^{a,*}, M. Stefanovic ^a, M. Zivkovic ^a, N. Grujovic ^a, B. Mistic ^b

^a Mechanical Engineering Faculty, University of Kragujevac,
S. Janjic 6, 34000 Kragujevac, Serbia and Montenegro

^b Technical College of Dobo, J

Kralja Dragutina 68, 74000 Dobo, Bosnia and Herzegovina

* Corresponding author: E-mail address: mandic@kg.ac.yu

Received 15.03.2006; accepted in revised form 30.04.2006

Analysis and modelling

ABSTRACT

Purpose: of this paper: The paper presents some results of extensive investigation of steel seam-welded tubes forming process, by applying combined treatment of material narrowing and expansion. The objective of executed numerical FE and experimental investigations was to determine the optimal technology for production of tubular product at simple tools and at the standard forming processing machines, without defects and with demanded dimensional accuracy.

Design/methodology/approach: Tube forming was done in one phase, in tool with two shaping spherical parts, that enables the expansion of the specimen's central zone and the filling of the die due to narrowing of the specimen ends, when certain conditions are achieved and with appropriate combination of influential process parameters (outer diameter, height and tube's wall thickness, as well as friction conditions). Series of physical and numerical FE experiments was performed.

Findings: Optimal dimensions of tubular product, with required process stability, were obtained this way. Also, results of experiments pointed out that the best process stability and die filling is achieved with specimens whose surfaces had previously been chemically treated. Results of numerical FE simulations of process are quite verified by experiments.

Practical implications: Obtained results have practical significance in solving similar processing problems. It also enables to investigate and broaden the knowledge on stability of these kinds of processes, beyond the scope of experimental investigations. Tubular product that is subjected to numerical-experimental investigation in this paper is prepared by narrowing it at both ends thus excluding the possibility to apply holder inside the tube.

Originality/value: Proposed method offers possibility for production of tubular products at simple forming machines and tools, without complex and expensive hydroforming equipment.

Keywords: Numerical techniques; Seam-welded tube forming; Narrowing; Expansion

1. Introduction

Tubular products formed by application of different forming methods or by their combination, have significant application nowadays in all industry branches, especially in a car industry, civil engineering, furniture production, etc. Beside basic forming methods like narrowing [1], expansion, stretching, external or

internal inversion [2,3], combination of two or more of mentioned methods are also applied in order to obtain products with different degree of geometrical complexity. One way to obtain the tubular product is to apply the hydroforming process [4-8] that assumes the complex and expensive equipment application. The other way is to apply more complex tools and multi-operation forming which lower the profitability of the process.

In this work, the combination of narrowing and expansion is applied where the expansion of the specimen's central zone and the filling of the die are done due to narrowing of the specimen ends when certain conditions are achieved and with appropriate combination of process parameters [9,10]. Tubular product that was subjected to experimental-numerical investigation, described in this paper, has been prepared by narrowing it at both ends, thus excluding the possibility to apply holder inside the tube.

Application of combined method of narrowing and expansion should consider stress state in referential areas. As shown in Figure 1, five areas in tubular specimen can be emphasized: 1- central area of free upsetting, 2-out of contact forming area, 3-narrowing area at spherical die portion, 4-bending area on die radius and 5-narrowing area in conical die portion.

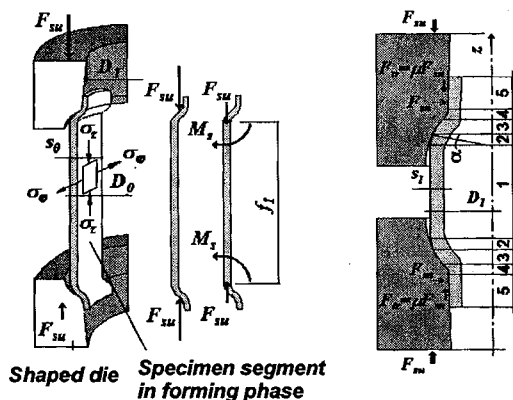

Fig. 1. Combined method of narrowing and expansion

The tube narrowing and expansion process is very unstable and sensitive to changes of narrowing coefficient and process parameters values (tube's diameter, height and wall thickness). Variation of parameters values produces changes of forming load and moment when the tube central zone extends. Production of tubular product without defects also depends on contact friction conditions between the material and the die.

The aim of this paper is to present comprehensive experimental and numerical FE simulation of forming process for RSt.37-2 seam-welded tubes at simple two piece tool mounting at hydraulic press. FE simulations and experiments were applied for monitoring the stability of tube's narrowing process under different conditions of processing. Numerical simulations confirmed that the required process stability is achieved with application of specimens with chemical preparation and with dimensional values $D_2H_2s_2$ (outer diameter $D_2=32\text{mm}$, height $H_2=69\text{mm}$ and tube's wall thickness $s_2=2.33\text{mm}$). Defects appear due to not filling or overfilling the die in all other numerical and physical experiments.

2. Problem statement

Tubular part shown in Figure 2 was investigated. No special exploitation characteristics are required from this tubular product, and it is economically admissible to use specimens like seam-welded tubes made of steel with low carbon content. The market price of final part also implied the application of cheaper material.

Regarding the fact that specimens are cut from seam-welded tubes, the material selection is conditioned by good weldability and formability.

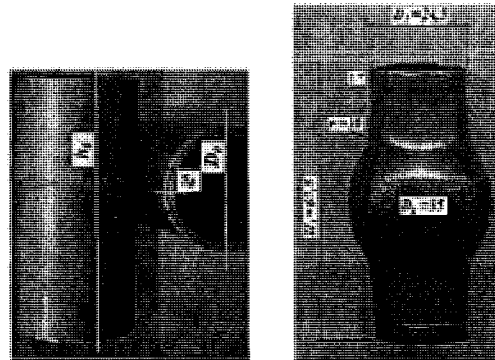

Fig. 2. Tubular specimen and part

2.1. Material and specimen parameters

Seam-welded tubes are made of RSt.37-2 (DIN 17100) on rolling lines MANNESMAN-MEER. Scaled-down test specimen has been prepared from sheet metal plate and tube sample. In order to obtain stress-strain curve, tensile tests have been carried out on KARL FRANC testing machine. Flow curves and approximated equations are shown in Figure 3.

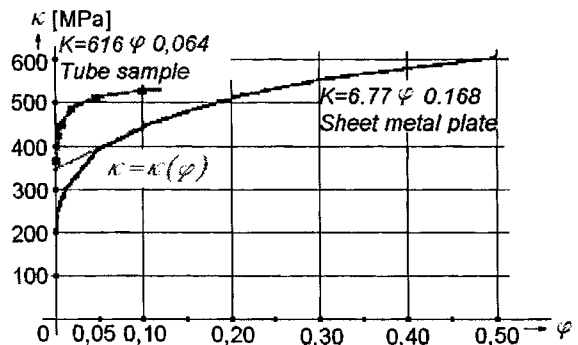

Fig. 3. Flow curve of RSt.37-2

Specimens were cut from seam-welded tubes, whose geometrical values were pre-limited by part dimensions and by afterward operations. Namely, the tube's wall thickness is conditioned by further welding operation at central spherical zone. Specimen's length is limited with later turning of tube ends at lathe, to demanded length.

Based on preliminary investigations and literature recommendations [11], all influential parameters regarding process stability, were determined as following: outer diameter - D , parts' height - H and tube's wall thickness - s , as well as contact friction conditions. Considering the optimal ratio of narrowing for tubular parts, the specimen's diameter should be about 10% lower than the ball's diameter ($D=31.85\text{mm}$).

According to the experimental investigation plan, values of influential parameters for process are determined as following: $D_1=31\text{mm}$, $D_2=32\text{mm}$, $D_3=33\text{mm}$, $H_1=68.5\text{mm}$, $H_2=69\text{mm}$, $H_3=69.5\text{mm}$, $s_1=2\text{mm}$, $s_2=2.33\text{mm}$, $s_3=2.5\text{mm}$.

2.2. Friction conditions

Contact friction conditions between the part and the tool changed as follows:

- M1 - application of machine oil ($\mu=0.13$),
- M2 - chemical preparation of the specimen - Zn phosphate + SAP G3 ($\mu=0.095$).

Friction coefficient values in both cases were determined by standard RING TEST method.

2.3. Equipment

Tube forming has been done in one phase. Tool consists of two shaping spherical parts made of hard metal, quality PV20. The tool was mounted on hydraulic press (see Figure 4), with nominal force of 320 kN. Ram speed was $v=0.023\text{m/s}$. During the forming process, load, as a function of time, was monitored by appropriate data acquisition equipment.

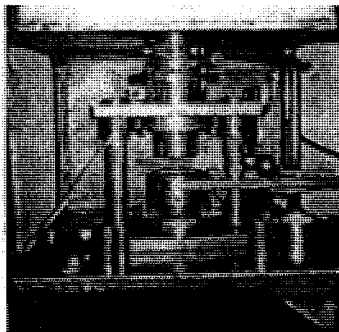

Fig. 4. Tool mounted on hydraulic press

3. FE simulations and experimental verification

FEM simulations were performed by application of CAMP form 2D program [12]. Program was developed based on finite element method with thermo-rigid-viscoplastic approach [13]. Program has module for automatic generating of FE mesh of quadrilateral 2D elements and remeshing, as well. It is designed for numerical simulation of 2D hot and cold bulk forming processes [14,15].

"Numerical experiments" are entirely compatible with experimental investigation plan, under the same processing conditions. The half of specimen was modelled, considering the existence of symmetry. Other input data for numerical simulation are shown in Table 1.

Experiments with two kinds of specimens were performed, with and without chemical preparation, in order to verify

numerical results. Experiments with specimens, whose surfaces had not previously been chemically treated but lubricated by machine oil, were unsatisfactory, but they pointed at directions in which dimensional parameters should be sought in the future. Application of specimens whose surface had previously been chemically treated yielded good results.

Table 1. Input data for FE simulations

1. Material properties	Flow stress	K (MPa)	677.0
	$\sigma = K \epsilon^n \dot{\epsilon}^m$	Exponent n	0.168
		Exponent m	0.0
2. Process conditions	Ram speed (mm/s)	23	
	Numerical time step (s)	0.05	
2. Contact friction	Friction factor for M1 lubricant	0.225	
	Friction factor for M2 lubricant	0.164	
3. Automatic generation of FE mesh	Size of FE element (mm)		
	Number of FE elements	306	
5. Remeshing parameters	Control of FE mesh	Size of elem.	
		Num. of elem.	400
	Max. allow. inter. angle of element	160	

4. Results and discussion

All physical experiments with machine oil as a lubricant produced specimens with defects as a consequence of not filling or overfilling the die. Specimens with defects are shown in Figure 5(a) and 5(b). Even though experiments with machine oil as a lubricant were unsatisfactory considering dimensional accuracy, they had given directions in which dimensional parameters values should be sought, in order to produce parts without defects.

Experiments with specimens with chemically prepared surfaces gave better results through what significant influence of contact friction on process stability was confirmed. Optimal combination of geometrically influential parameters is $D_2H_2S_2$, for which the tubular part with demanded dimensional accuracy is obtained without defects (see Figure 5(c)). Analysis of forming load values for all experiments indicated that small load is not enough to form the specimen sphere, while with higher load the expansion of the specimen's central zone begins too soon and overfilling of the tool occurs.

Numerical FE simulations confirmed that the best process stability and die filling is achieved with specimens with chemical preparation (M2) and for dimensional values $D_2H_2S_2$. In all other numerical experiments defects appear due to not filling or overfilling the die. Only some of numerical experiments results are shown in Figure 5, which illustrate irregular material flow (a and b case) and regular material flow (c case). By analysis of strain-stress fields reasons for process instability and defects appearance can be explained in some extent and in that way obtained changes of influential factors values and optimal design solution for production technology can be obtained.

In all numerical experiments evaluations for deformation forces are obtained. Comparative load-stroke diagram for tubes narrowing processes for some specimens with chemical preparation are shown on Figure 6.

Forming load course during the process and its maximum values correspond to the experimental values with satisfactory accuracy. Influence of specimen geometrical changes and of friction conditions on the course and on the value of load, can be monitored through analysis of diagram.

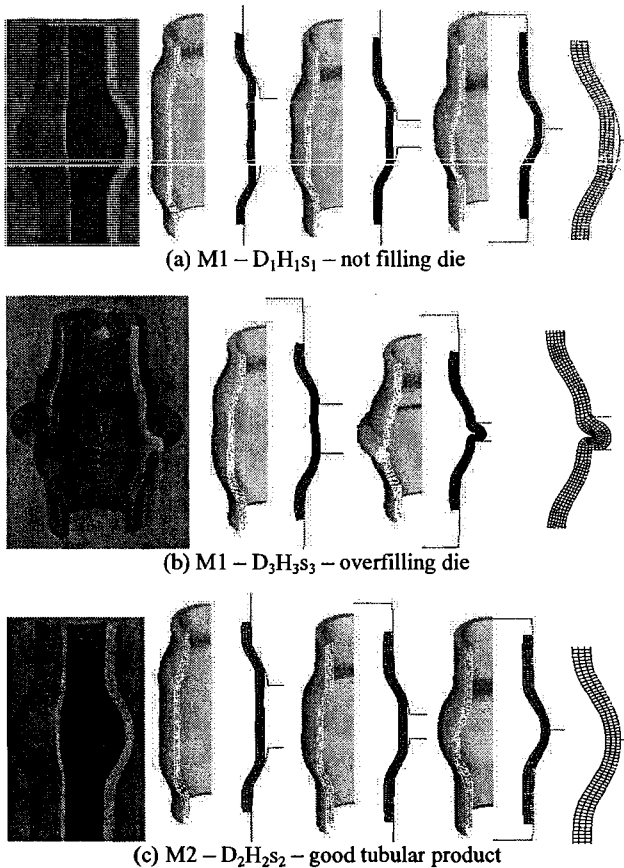

Fig. 5. Physical and numerical models of tubular specimens

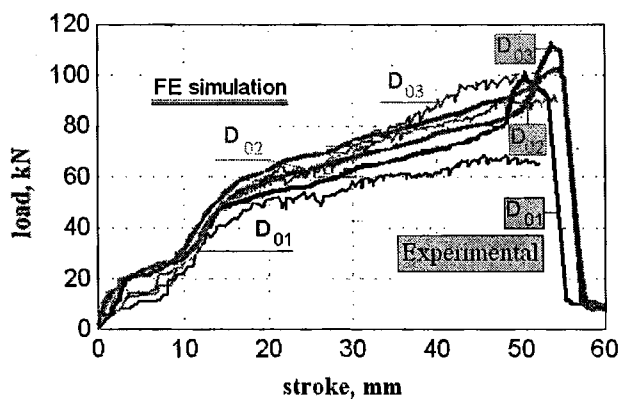

Fig. 6. Comparative load-stroke diagrams, $H_2=69\text{mm}$, $s_2=2.33\text{mm}$

5. Conclusions

1. Dimensional accuracy of specimen is achieved by combination of narrowing (narrowing coefficient $k_n=0.76$) and expansion (expansion coefficient $k_e=0.91$) processes.

2. By determining optimal values for influential parameters of process ($D=32\text{mm}$, $H=69\text{mm}$, $s=2.33\text{mm}$), as well as through establishing of friction conditions ($\mu=0.095$) that provide process stability, specimens with demanded dimensional accuracy were obtained.
3. Contact friction has significant influence on process stability due to which chemical preparation of tubular specimens is necessary.
4. A general good agreement was found between numerical FE and experimental results throughout the study.

References

- [1] B. Mistic, M. Sljivic, Production development of one axial-symmetrical work-piece out of seam tube through necking-in method, *Journal for Technology of Plasticity* (2001) 27-33.
- [2] P.A.R. Rosa, J.M.C. Rodrigues, P.A.F. Martins, External inversion of thin-walled tubes using a die: experimental and theoretical investigation, *International Journal of Machine Tools & Manufacture*, 43 (2003), 787-796.
- [3] P.A.R. Rosa, J.M.C. Rodrigues, P.A.F. Martins, Internal inversion of thin-walled tubes using a die: experimental and theoretical investigation, *International Journal of Machine Tools & Manufacture*, 44 (2004), 775-784.
- [4] M. Koc, T. Altan, Application of two dimensional (2D) FEA for the tube hydroforming process, *International Journal of Machine Tools & Manufacture*, 42 (2002), 1285-1295.
- [5] Y-M. Hwanga, T. Altan, Finite element analysis of tube hydroforming processes in a rectangular die, *Finite Element in Analysis and Design*, 39 (2002), 1071-1082.
- [6] J.P. Abrantes, A. Szabo-Ponce, G.F. Batalha, Experimental and numerical simulation of tube hydroforming (THF), *Journal of Materials Processing Technology* 164-165 (2005), 1140-1147.
- [7] J.B. Yang, B.H. Jeon, S.I. Oh, Design sensitivity analysis and optimization of the hydroforming process, *Journal of Materials Processing Technology* 113 (2001), 666-672.
- [8] F. Vollersten, M. Plancak, On possibilities for the determination of the coefficient of friction in hydroforming of tubes, *Journal of Materials Processing Technology* 125-126 (2002), 412-420.
- [9] B. Mistic, Stability of narrowing process of steel seam-welded tubes, Ph.D. Thesis (in Serbian), Banja Luka, June 2004.
- [10] V. Mandic, B. Mistic, Stability of steel seam-welded tubes forming process - experimental and numerical investigation, 8th International Conference on Technology of Plasticity, ICTP, 9-13 October 2005, Verona, Italy, pp. 209.
- [11] K. Winsel, E. Liebscher, Einziehen und Aufweiten von Rohrabschnitten VEB Armaturenwerk Prenzlau im VEB Armaturenkombinat, *Umformtechnik*, 24 (1990) 2.
- [12] Y.T. Im, A computer-aided-design system for forming processes, *Journal of Materials Processing Technology* 89-90 (1999), 1-7.
- [13] S. Kobayashi, S.I. Oh, T. Altan, *Metal Forming and the Finite-Element Methods*, Oxford University Press, 1989.
- [14] V. Mandic, Physical modelling and numerical simulation as basis of new concept in die design of hot bulk forming processes, Ph.D. Thesis (in Serbian), Kragujevac, 2002.
- [15] P.B. Hussain, J.S. Cheon, D.J. Kwak, S.J. Kim, Y.T. Im, Simulation of clutch-hub forging process using CAMPform, *Journal of Materials Processing Technology* 123 (2002), 120-132.